

# ENGINEERING NOTES

**T**here are several indicators of quality air handling units: low cabinet leakage, cabinet strength, ease of maintenance, resistance to cabinet sweating, and longevity, just to name a few. ClimateCraft has developed a custom air handling unit that addresses the customer's primary needs by utilizing the most modern production processes of any AHU manufacturer. The final product is the highest quality air handling unit on the market today.

## TRADITIONAL METHODS OF CABINET CONSTRUCTION

Before automated manufacturing and personal computers, one of the simplest and best methods to produce a custom air handling unit was to make a structural frame. A frame offered a strong cabinet and construction flexibility with minimal engineering.

However, utilizing modern technology, these old methods are no longer required. Most of the custom manufacturers today that use welded frame construction are still using the same labor-intensive and error-prone construction methods that were developed decades ago. The weaknesses in the frame construction far overshadow the strengths.

- Welded frame construction is labor-intensive, introducing the possibility for mistakes. Quality is sacrificed in comparison to modern precision manufacturing automation.
- The frame must be cut and re-welded to service major internal equipment.
- Rust and corrosion are more likely to occur with painted tube versus galvanized metal.

Cabinet strength has always been a key indicator of the quality of an air handling unit. A strong cabinet is able to withstand snow loads and wind loads during storms, resist cabinet leakage, and prevent the likelihood of damage during unit shipment.

Typically, air handling units with panels that deflect excessively will tend to leak excessively. The cabinets may be tight at low pressures, but the panel deflection at higher pressures will cause panel seals to leak. Weak cabinets may be tight at the factory but the truck ride to the job site can result in a leaky cabinet.

The drawings at the bottom of this page illustrate moments of inertia for the panel joints of several major custom air handling unit manufacturers. The higher the moment of inertia, the stronger the joint.

A much simpler and less error prone method of unit construction is to eliminate the cabinet frame (see Figure 4 below). However there can be several disadvantages in the typical cabinet design that does not use a frame.

*Typical panel joint construction of two-inch insulated cabinet with 16 gauge steel outer liner and 20 gauge steel inner liner.*

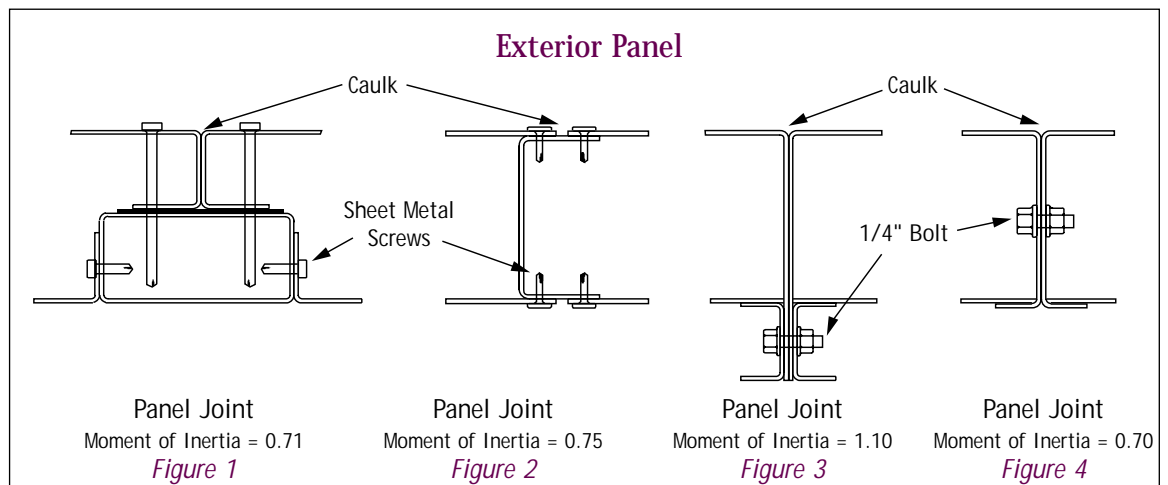

*ClimateCraft's unique roll-formed panel construction results in a unit cabinet that is significantly stronger than framed units that are welded. Sturdy 5/16 inch bolts are used to join panels instead of insubstantial sheet metal screws.*

- Thermal break construction is often very expensive or not an option.
- The panel fasteners that are hidden are difficult to access. Servicing major internal components is time consuming and expensive.
- The lack of frame and panel support can create a unit that will collapse when removing panels for servicing major internal components. This type of unit can be more of a service problem than using a cutting torch and welder that is required to service welded frame units.
- Panel sealants are exposed to the UV light of the sun and weather. The probability of cabinet leakage in just a few years after installation is increased dramatically due to the degradation of the sealing material.

## CLIMATECRAFT

ClimateCraft has embraced manufacturing methods that utilize the latest in technology and automation. Antiquated, labor-intensive construction practices have been abandoned for innovative, state-of-the-art manufacturing methods and designs. This precision manufacturing automation process creates the highest quality cabinet on the market today.

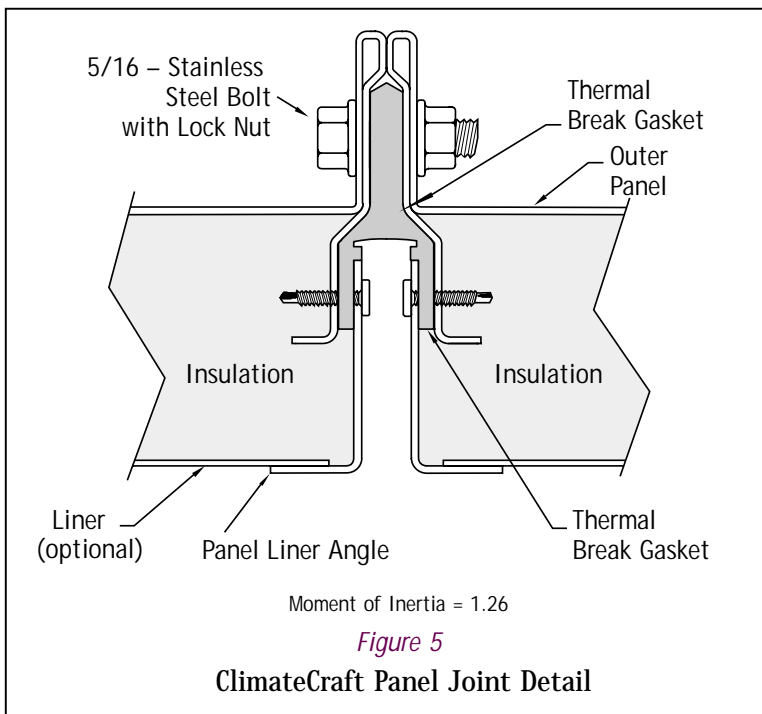

ClimateCraft's unique panel design incorporates the strength of a unit with framed construction and the ease of service of a paneled unit. The moment of inertia of the ClimateCraft panel joint is greater than the typical framed unit (see Figure 5 below).

ClimateCraft's cabinet construction incorporates a top rail that enables panels to be removed without compromising the integrity of the rest of the cabinet. The cabinet will not collapse like conventional panel-only units.

A thermal break design is standard with ClimateCraft's design. Cabinet sweating is eliminated in most applications. Unlike many manufacturers (as illustrated in Figures 1 through 4 on the previous side), ClimateCraft's panel has been designed so that the cabinet sealing material is protected from UV light and the weather. This dramatically extends the life of the gasket.

Stainless steel bolts are used for securing the panels. Most custom manufacturers use sheet metal screws that have a fraction of the strength of bolts. Sheet metal screws are also difficult, if not impossible, to reuse after the panel is removed. The stainless steel bolts are on the outside of the cabinet for easy access and removal.

## STANDARD FEATURES

- ETL label for entire unit
- Full thermal break panels
- Stainless steel panel bolts on the outside for easy access.
- Stainless steel door frame
- Full thermal break door frames
- Strong panels with high moments of inertia
- Fully removable panels (without cutting, roof removal or welding required)
- Leak class 6 construction
- Doors swing against static pressure
- Airfoil low-leak dampers
- Made in the USA

ClimateCraft's construction methods are the newest and most modern of any custom manufacturer in the world. Although some custom manufacturers have the ability to incorporate the type of features listed above for an additional cost, most leave them out. This significantly lowers the quality of their units. ClimateCraft units have the strength of a welded frame unit *without* the disadvantages.

*ClimateCraft reserves the right to continually improve its products and to change the design and specifications without notice.*



A SUBSIDIARY OF LSB INDUSTRIES, INC.

P.O. Box 1538, 1427 N.W. 3rd, Oklahoma City, OK 73101-1538

Phone: (405) 415-9230 Fax: (405) 415-9231 [www.climatecraft.com](http://www.climatecraft.com)